

# ZENMUSE H30 SERIES

## User Manual

v1.0 2024.05

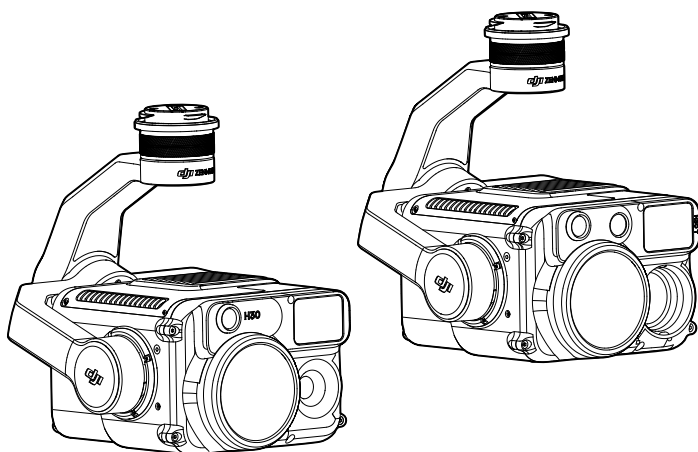



This document is copyrighted by DJI with all rights reserved. Unless otherwise authorized by DJI, you are not eligible to use or allow others to use the document or any part of the document by reproducing, transferring or selling the document. Users should only refer to this document and the content thereof as instructions to operate DJI UAV. The document should not be used for other purposes.

### **Searching for Keywords**

Search for keywords such as “battery” and “install” to find a topic. If you are using Adobe Acrobat Reader to read this document, press Ctrl+F on Windows or Command+F on Mac to begin a search.

### **Navigating to a Topic**

View a complete list of topics in the table of contents. Click on a topic to navigate to that section.

### **Printing this Document**

This document supports high resolution printing.

# Using This Manual

## Legends

 Important

 Hints and Tips

## Video Tutorials

Go to the official website to watch the tutorial videos, which demonstrate how to use the product safely.

## Warnings

1. When not in use, store the ZENMUSE™ H30 series in the storage case and replace the desiccant packet as necessary to prevent fogging on the lenses due to excessive ambient humidity. If the lenses fog up, the water vapor will usually dissipate after powering on the device for a while. It is recommended to store the product in an environment with a relative humidity of less than 40% and temperature of  $20\pm 5^{\circ}\text{C}$ .
2. DO NOT expose the infrared camera lens to a strong energy source such as the sun, lava, or laser beams. The temperature of the observed subjects should not exceed  $800^{\circ}\text{C}$  ( $1472^{\circ}\text{F}$ ) (or not exceed  $1600^{\circ}\text{C}$  ( $2912^{\circ}\text{F}$ ) with an Infrared Density Filter installed). Otherwise, it will burn the infrared sensor and cause irreversible damage.
3. DO NOT place the product under direct sunlight, in areas with poor ventilation, or near a heat source such as a heater.
4. DO NOT repeatedly power the product on or off. After powering off, wait at least 30 seconds before powering back on. Otherwise, the product life will be affected.
5. Under controlled laboratory conditions, the product achieves an IP54 protection rating by IEC60529 standards. The protection rating is not permanent and may reduce over an extended period.
6. Make sure there is no liquid on the surface or in the port of the gimbal before installation.
7. Make sure the gimbal is securely installed on the aircraft and the microSD card slot cover is closed properly.
8. Make sure the surface of the gimbal is dry before opening the microSD card slot cover.
9. DO NOT insert or remove the microSD card during use.
10. DO NOT touch the surface of the lenses with your hand. Be careful to avoid scratching the surface of the lenses with sharp objects. Otherwise, the quality of images may be affected.
11. Clean the surface of the camera lenses with a soft, dry, clean cloth. DO NOT use alkaline detergents.
12. DO NOT drop the product and handle with care. Otherwise, it may not function properly.
13. The image quality of the infrared thermal camera may be affected with an infrared density filter installed.

# Contents

<b>Using This Manual</b>	<b>1</b>
Legends	1
Video Tutorials	1
<b>Warnings</b>	<b>1</b>
<b>Product Profile</b>	<b>3</b>
Introduction	3
Overview	3
Installation	4
Activation	5
<b>Basic Operations</b>	<b>5</b>
Remote Controller Controls	5
DJI Pilot 2 App	6
Zoom Camera	6
Wide-Angle Camera	9
Infrared Thermal Camera*	10
<b>Using the Camera</b>	<b>12</b>
Setting the Shooting Mode	12
Camera Functions	13
Visible Light Camera	13
Infrared Thermal Camera	14
General Settings	15
<b>Maintenance</b>	<b>16</b>
Log Export	16
Firmware Update	16
Using DJI Pilot 2	16
Using microSD Card	16
Update Status Alarm	17
<b>Appendix</b>	<b>18</b>
Specifications	18
Infrared Parameters	22
Palettes	22
Emissivity	23

# Product Profile

## Introduction

Both Zenmuse H30 and 30T have integrated zoom and wide-angle cameras, which enables users to quickly switch to a highly magnified zoom view for detailed observation after recognizing an object in the wide-angle camera view. The observation performance at night and in low-light environments is improved with the NIR auxiliary light, and the equipped laser rangefinder can provide the distance and location information of the subject. H30T also features a long-wave infrared thermal camera, which can capture thermal images.

With a 3-axis stabilized gimbal, the H30 series can be used with compatible DJI aircraft and stream live video to the DJI PILOT™ 2 App. The upgraded Night Scene mode and Smart Capture mode allow a wider range of usage scenarios.

## Overview

### H30

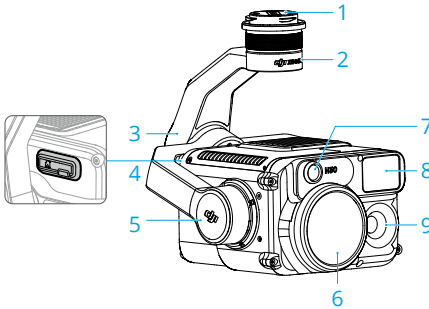

1. Gimbal Connector
2. Pan Motor
3. Roll Motor
4. microSD Card Slot
5. Tilt Motor
6. Zoom Camera
7. NIR Auxiliary Light
8. Laser Range Finder
9. Wide-Angle Camera
10. Infrared Thermal Camera

### H30T

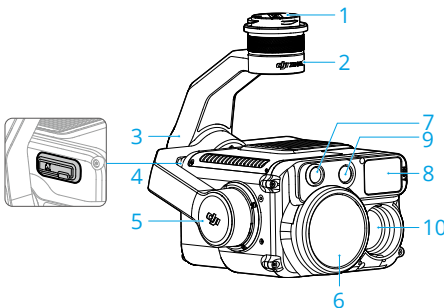

## Installation

H30 series can be mounted to MATRICE™ 350 RTK and Matrice 300 RTK aircraft (requires DJI RC Plus). The H30 mounted to the Matrice 350 RTK aircraft is used as an example.

1. Remove the gimbal cap and lens protector.

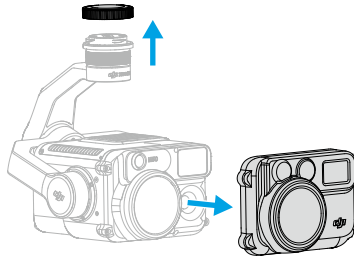

2. Press and hold the button on the aircraft used for detaching the gimbal and camera. Rotate and remove the gimbal cap on the aircraft.
3. Align the white dot on the gimbal with the red dot on the aircraft and insert the gimbal.
4. Rotate the gimbal connector to the locked position by aligning the red dots.

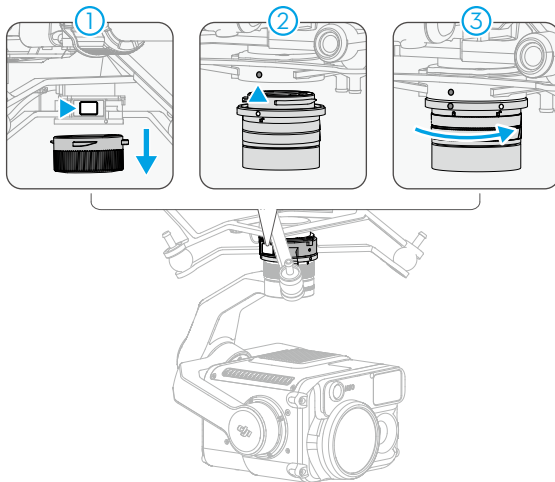

- 
- ⚠ It is necessary to perform Gimbal Auto Calibration to ensure image quality when the payload is mounted onto different gimbal connectors.
  - Make sure the gimbal connector on the aircraft is positioned correctly when mounting. Otherwise, the payload cannot be mounted.
  - Only remove the payload after powering off the aircraft.
-

- ⚠ • Remove the payload by pressing the button on the aircraft and rotating the payload.
- Make sure the microSD card slot cover is firmly in place to prevent dust or moisture entering during usage or transportation.
- Detach the gimbal from the aircraft during transportation or storage. Otherwise, the service life of the damper balls may be shortened or they may even be damaged.

## Activation

The Zenmuse H30 series requires activation via DJI Pilot 2 before first use. Mount it on the aircraft, then power on the aircraft and remote controller and follow the on-screen instructions to activate using the DJI Pilot 2 app. An internet connection is required for activation.

## Basic Operations

### Remote Controller Controls

With the buttons on the DJI RC Plus remote controller, users can switch between different camera views, adjust the camera zoom, and control the gimbal and camera.

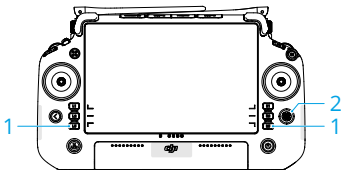

1. L1/L2/L3/R1/R2/R3 Buttons: Go to Camera View in DJI Pilot 2 to view the specific functions of these buttons. Refer to the DJI Pilot 2 App section for details.

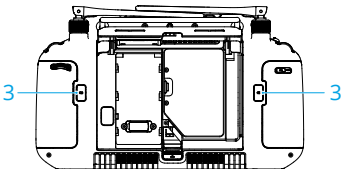

2. 5D Button\*
3. Customizable C1/C2/C3 Buttons\*
4. Left Dial: Adjusts the tilt of the gimbal.
5. Record Button: Press once to start or stop recording.
6. Focus/Shutter Button: Press the button halfway down to autofocus and all the way down to take a photo.
7. Right Dial: Adjusts the pan of the gimbal.
8. Scroll Wheel: Adjusts the zoom magnification level.

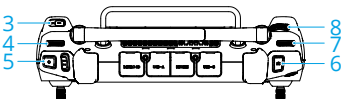

\* The function of these buttons can be customized in the DJI Pilot 2 app.

## DJI Pilot 2 App

The DJI Pilot 2 app provides professional photography configurations. The visual cameras support advanced functions such as Smart Capture mode and Night Scene mode. The infrared thermal camera provides high-res review and users can set the environment parameters to improve the temperature measurement accuracy.

- ☀️ • Features marked with \* are only available on Zenmuse H30T.
- The following image is for reference only. The actual interface varies according to the app version.

### Zoom Camera

After tapping Enter Camera View on the home screen of DJI Pilot 2 and completing the Preflight Check, users will be directed to the camera view. Below is an illustration using the zoom camera as the main view on the remote controller.

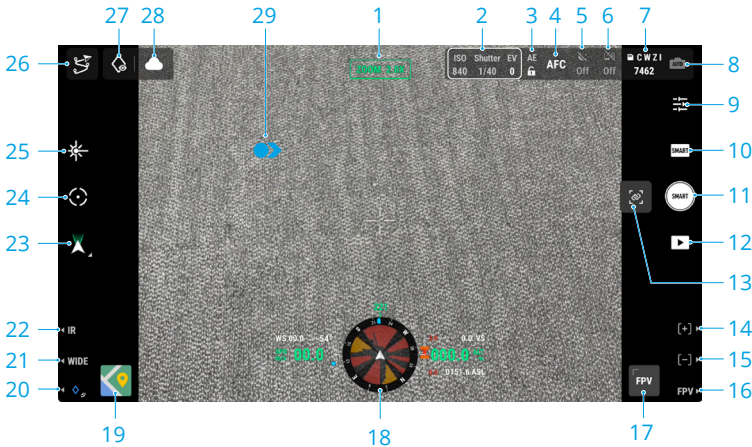

#### 1. Camera and Zoom

Displays the camera for the current liveview and its zoom ratio.

#### 2. Camera Settings

Displays the current camera parameters.

#### 3. Auto Exposure Lock

Tap to lock the current exposure value.

#### 4. Focus Mode

Tap to switch between MF (manual focus), AFC (continuous autofocus), and AFS (single autofocus).



## 5. Night Scene

Tap to enable or disable Night Scene mode. Enhanced Noise Reduction, IR Light, and NIR Illumination are available when Night Scene mode is enabled. Refer to the [Using the Camera](#) section for details.

## 6. Electronic Dehazing

Tap to enable or disable Electronic Dehazing. Refer to the [Using the Camera](#) section for details.

## 7. Storage Info and Storage File Type Selection

Displays the remaining number of photos or the duration of video for the microSD card. Tap to select the storage file type: current camera view, wide-angle, IR, or zoom.

## 8. Exposure Settings

The H30 series supports Auto and M exposure modes. Only Auto mode is available when using Smart Capture mode.

## 9. Camera Settings

Tap to enter the camera setting menu. The settings may vary depending on the camera type and shooting mode. Switch to different camera types and shooting modes to view the settings. Refer to the [Using the Camera](#) section for details.

## 10. Photo/Video Mode

Tap to select different shooting modes. Refer to the [Using the Camera](#) section for details.

## 11. Shutter/Record Button

Tap to take photos or start or stop recording.

## 12. Playback

Tap to view and download photos or videos stored on the aircraft microSD card.

## 13. Link Zoom\*

Tap to enable or disable Link Zoom. Once enabled, adjusting the zoom ratio of the zoom camera will change the zoom of the infrared thermal cameras simultaneously. The maximum zoom ratio of infrared thermal camera is 32x. When the zoom ratio of the zoom camera is adjusted to 32x or above, the infrared thermal camera will remain at 32x and no longer increase.

14. Press the R1 button on the remote controller, and the camera lens will zoom in. The maximum ratio is 400x.

15. Press the R2 button on the remote controller, and the camera lens will zoom out.

Press the R3 button on the remote controller to switch to FPV camera view.

## 17. FPV Camera View

Tap to display the FPV camera view on the screen. Users can maximize or minimize the view.

## 18. Navigation Display

In Camera View, the horizontal speed, wind speed, gimbal pitch angle and pitch scale, and the inclination of the gimbal relative to the ground are shown on the left of Navigation Display. The right shows the absolute altitude, relative altitude, vertical obstacle sensing information, and vertical speed bar.

### 19. Map View

Tap to display the map view on the screen. Users can maximize or minimize the view.

### 20. Laser PinPoint

Press the L3 button on the remote controller to add a PinPoint in the center of the screen. Tap to select a PinPoint on the map to view the distance between the subject and the aircraft, the absolute and relative altitude, latitude and longitude of the subject. The laser points can be projected onto the live view.

21. Press the L2 button on the remote controller to switch between the wide-angle camera view and the zoom camera view.

22. Press the L1 button on the remote controller to switch between the visible light camera view (wide-angle camera or zoom camera) and the infrared camera view.\*

### 23. Gimbal Mode

Displays the current gimbal status as follow mode. Tap to select an action such as gimbal recenter, gimbal pan recenter, gimbal tilt down, or gimbal down, or switch to gimbal free mode.

### 24. Smart Track

Tap to enable Smart Track and use the H30 series to track subjects such as people, vehicles, or boats. After recognizing and locking the subjects, it will automatically rotate the gimbal to situate the subject in the center of the screen, and adjust the camera focal length to an appropriate focus rate to track and view the subject.



- Enabling Night Scene mode may reduce the camera frame rate, which will affect tracking effects.
- 

### 25. Laser Rangefinding (RNG)

Tap to enable RNG. The crosshair in the center of the liveview will turn red, which means the laser rangefinder is pointing at the subject and measuring the distance between the subject and the aircraft, as well as the absolute altitude, latitude, and longitude of the target.

RNG positioning may be affected in the following conditions:

- The measuring range may decrease and the rangefinding result may be unstable when used in low-visibility environments such as rainy or foggy weather.
- The rangefinding result may be unstable when pointed at subjects with reflective surfaces.
- If there are multiple subjects in the view or the subjects are small or blocked, the object in the center of the screen may not be the measured subject, so the rangefinding result may be unstable.

### 26. Flight Route

Tap to enter the flight route library. Users can create and view all flight tasks and more.

## 27. Look At

After selecting a PinPoint, users can tap the Look At icon, and the camera will face the PinPoint.

## 28. Status of Photo/Video Upload to Cloud

Displays the file upload status from DJI Pilot 2 to DJI FlightHub 2 or the live stream connection status. Tap to view the details. If the DJI FlightHub 2 cloud service is enabled, users can quickly configure the media file upload settings.

## 29. Screen Gestures

Double-tap anywhere on the main screen, and the gimbal will automatically rotate to place the tapped point in the center of the screen.

Tap and hold the screen with one finger until the cursor appears, and then swipe your finger to adjust the gimbal angle.

Swipe down with three fingers to hide the settings on the screen.

## Wide-Angle Camera

This section mainly sets out the differences with the zoom camera. Refer to the Zoom Camera section for more details.

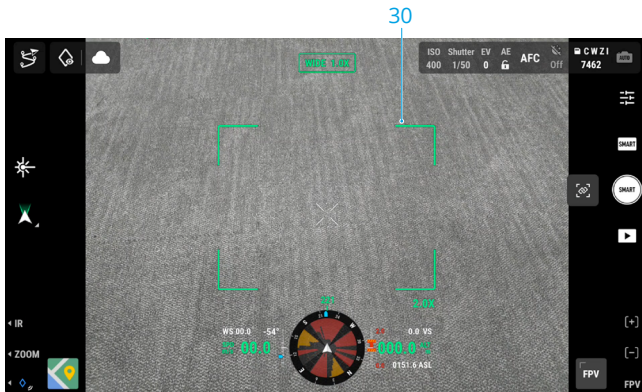

30. Zoom Frame: After switching to the wide-angle camera as the main view, the zoom frame will display the field of view and camera zoom ratio.

## Infrared Thermal Camera\*

This section mainly sets out the differences with the zoom camera. Refer to the Zoom Camera section for more details.

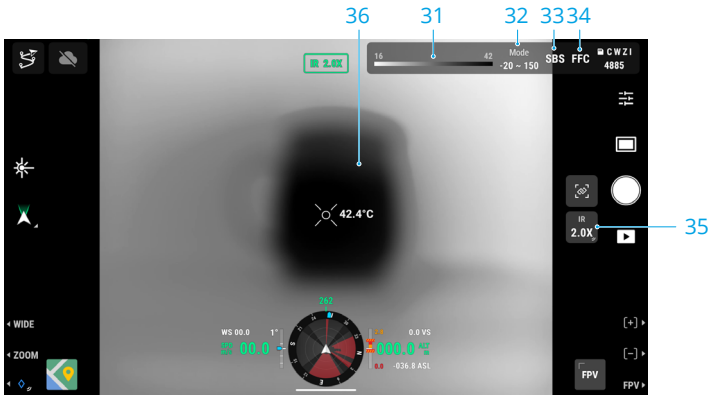

### 31. Palette/Isotherm

The numbers in the two ends of the chroma bar display the highest and lowest temperature measurement values. Tap the chroma bar to select different infrared temperature measurement [palettes](#).

Tap  to enable Isotherm and set temperature measurement intervals, so that objects within the designated temperature range will be more easily visible.



- The setting will not take effect if the measured area exceeds the maximum or minimum temperature measurement values of the current view.

### 32. Gain Modes

Tap to select different gain modes and adjust the temperature measurement range:

- The High Gain mode offers more precise temperature measurement capabilities, with a measurement range of -20° to 150° C (-4° to 302° F).
- The Low Gain mode provides a broader temperature measurement range, from 0° to 600° C (32° to 1112° F).
- The High-Res mode is designed for observing objects with small temperature differences. Temperature measurement is not supported in this mode.



- The camera view may exhibit uneven dark or bright areas if the High-Res mode is enabled immediately after powering on. The image will return to normal after using it for a while. Performing FFC calibration once can reduce the unevenness of the view. It is not recommended to continuously perform FFC calibration, which may cause the shutter to overheat and affect quality of the image.

### 33. Single/Side-By-Side View Toggle

Tap to enable or disable side-by-side view. When enabled, both the infrared and zoom view will be displayed side by side.

### 34. FFC Calibration

Tap to perform FFC calibration. FFC calibration is a function of the infrared thermal camera that optimizes image quality for easy observation of temperature changes.

During calibration, the app view will pause for approximately one second and the camera will make a clicking sound.

### 35. Zoom (Infrared Thermal Camera)

Tap to adjust the digital zoom of the infrared thermal camera, which has a maximum zoom capability of 32x. Tap and hold to zoom directly to 2x. Once Link Zoom is enabled, this icon will disappear automatically.

### 36. Temperature Measurement

**Spot Measurement:** Tap on any spot in the infrared thermal camera view to display the temperature of that spot.

**Center Point Temperature Measurement:** Tap on the center point in the infrared thermal camera view to display the temperature at that point for higher precision measurements. Tapping outside the center point exits the Center Point Temperature Measurement mode.

**Area Measurement:** Frame to select any area in the infrared thermal camera view to display the highest temperature and lowest temperature within that area, along with their locations. Tap the icons to perform these functions:

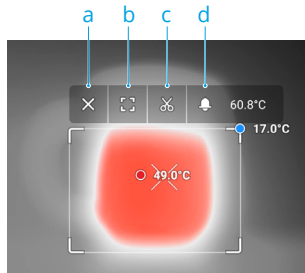

- Exit the area measurement.
- Maximize the selected area.
- Take a screenshot of the measurement result.
- Enable/disable Temperature Alert and set alert temperature. Once the highest temperature exceeds the set alert temperature, the remote controller will issue a warning sound.

# Using the Camera

## Setting the Shooting Mode

Tap the Photo/Video Mode button to select different shooting modes.

### Smart Capture

Smart Capture mode allows the camera to automatically adjust parameters based on different scenes and lighting conditions to achieve higher-quality photo results. However, the shooting speed may be slower compared to Single Shot mode.

### Single Shot

Tap the shutter button to take a single photo.

### Interval

In this mode, the camera will automatically take photos at the setting intervals (0.7/1/2/3/5/7/10/15/20/30/60 s) after tapping the shutter button.

### Panorama

Panorama is available after takeoff. When enabled, the current view will switch to wide-angle camera view. Users cannot adjust the zoom ratio or switch the camera view in this mode. The gimbal moves automatically and the wide-angle camera takes a series of photos at the current zoom ratio, and then combines them into a panoramic photo.



- Toggle the flight mode switch on the remote controller to N mode before taking a panorama.
- 

### High-Res Grid Photo

The live view will switch to the wide-angle camera view. Drag to select an area and set the target shooting area by re-sizing or moving the white grid on the screen, and zooming in or out as needed.

Tap the shutter button to take a series of photos of the selected area at the current zoom ratio with the zoom camera and one photo with the wide-angle camera.

### Video

Different resolution options are available when taking videos. The zoom camera and wide-angle camera support recording at 3840×2160 and 1920×1080 (Night Scene mode off).

Pre-Recording is available when taking videos. Tap  to enable Pre-Recording and select duration. The recorded video will include the image of the set duration before tapping the shooting button.

## Camera Functions

### Visible Light Camera

The functions below are available when the camera view is the zoom or the wide-angle camera view.

#### Night Scene

Night Scene mode can optimize imaging in low-light environments. The setting applies to both the zoom camera and the wide-angle camera.

When selecting Auto, Night Scene mode will be enabled automatically in low-light environments.

When manually enabled, users can set the following settings:

**Enhanced Noise Reduction:** Further decrease the recording frame rate to achieve better image quality.

**IR Light:** When enabled, the live view turns to a grayscale image by removing the IR filter.

**NIR Illumination:** When enabled, the NIR auxiliary light will turn on after takeoff to provide additional illumination to the center of the view. IR light will also start simultaneously. NIR auxiliary light will turn off automatically after landing.

IR Light and NIR Illumination are only available when using the zoom camera.

- 
-  • It is recommended to enable NIR illumination in no-light conditions (less than 0.1 lux, such as starlight or black-light conditions) and only enable Night Scene in non-black-light environments (more than 0.1 lux, such as urban nightscapes or full moon).
  - The illumination effect may be negatively affected when used in weather conditions like rain, fog, haze, or snow.
  - The auxiliary light beam cannot cover the whole field of view when the zoom ratio is below 10x, so the illumination effect will be affected.
- 

#### Electronic Dehazing

The function is only available when using the zoom camera, improving the imaging clarity in environments with fog, haze, or high atmospheric humidity.

It will automatically turn on to optimize the imaging clarity when Auto has been selected. If manually enabled, the dehazing level can be set as Low or High.

- 
-  • Night Scene mode and Electronic Dehazing cannot be used at the same time. Electronic Dehazing will not take effect with Night Scene mode enabled.
-

## Infrared Thermal Camera

When the main screen shows the infrared thermal camera view, tap  to enter camera settings to enable the functions below.

### Region of interest (ROI)

Users can select the ROI according to the scene and their requirements.

**Full Screen:** Select to evenly distribute the color spectrum across the entire image.

**Sky Excluded:** Select to ignore areas of the sky so that most of the spectrum can be allocated to the remaining areas.

Therefore, if there is a large patch of sky in the image, you can select Sky Excluded and the areas except the sky will have higher contrast, enhancing observation.

### Scenes

Users can select a scene from Manual, Default, and Inspection according to the actual situation. After selecting Manual, users can set and save custom parameters. When selecting Default or Inspection, the camera will automatically apply the following properties to obtain the best result.

**DDE (Digital Detail Enhancement):** Enhance image details and/or suppresses fixed pattern noise.

**Contrast:** The ratio of black and white in the image. Colors will be richer and have more contrast when the value is high.

**Brightness:** The brightness of the image.

### Auto FFC

Once enabled, the infrared thermal camera will automatically calibrate at regular intervals.

### Auto UHR Infrared Image

When enabled, UHR (Ultra-High Resolution) Infrared Image mode will automatically activate when the infrared thermal camera is at 5x zoom or higher, providing clear infrared images.



• UHR Infrared Image is unavailable when Night Scene mode is enabled.

---

### Sun Burn Protection

When enabled, the infrared shutter automatically closes in strong sunlight.

### Infrared Thermometry Parameters<sup>[1]</sup>

Temperature measurement accuracy is affected by various factors. It is recommended to set the environment parameters to improve the accuracy.

**Emissivity of objects:** The emissivity of the object will affect temperature measurement accuracy. Generally, accuracy increases proportionally to emissivity. Refer to [Infrared Parameters](#) section for emissivity of common objects.

**Temperature measurement distance:** The distance can be set from 1 to 300 m. The real-time RNG value is for your reference when the Laser Rangefinding or Center Point Temperature Measurement is enabled.



**Air humidity:** Temperature and humidity resistance has been calibrated before delivery, but extreme humidity levels will affect measurement accuracy. So you can set the humidity of current environment to improve the accuracy.

**Temperature:** When selecting Auto, the temperature value detected by the sensor will be used. You can also set the temperature manually.

[1] When measuring a blackbody 13 m away at 25° C in a windless indoor environment without the infrared density filter, the infrared thermal camera provides an accuracy of  $\pm 2^{\circ}$  C or  $\pm 2\%$  (whichever is the larger value) when using the High Gain mode, and an accuracy of  $\pm 5^{\circ}$  C or  $\pm 3\%$  (whichever is the larger value) when using the Low Gain mode. Since the emissivity of different blackbodies varies, this measurement result only represents the accuracy of tested blackbodies and is for reference only. It is recommended to set the correct thermometry parameters to improve the accuracy.

## General Settings

Create Folder	Create a folder manually on the microSD card of the gimbal and camera to store photos and videos, with customizable folder names.
LEDs Off While Shooting	Once enabled, Frame Arm LEDs will turn off automatically during shooting and recording.
Timestamp	Customized timestamp can be created when enabled, including information such as payload model and SN, coordinates, altitudes, date and time. Timestamp location can also be customized.
Grid	Enable or disable the gridlines or diagonal lines.
Laser Module	Enhanced Mode: In this mode, functions including Smart Track, PinPoint, RNG, and Center Point Temperature Measurement are able to work normally. It will be reset to Enhanced after the camera is restarted.  On-Demand Mode: In this mode, the laser module will only be enabled when required. Laser Assisted AF is disabled and the camera focus performance is decreased.
Reset Camera Settings	Tap to reset the camera to the default settings.
Format Memory Card	Tap to format and remove all content from the microSD card. Operate with caution.
Lens Defog	Tap the button and then the gimbal camera will continuously warm itself up to dissipate the moisture on the lens.
Video Caption	Video Caption can be enabled when the shooting mode is video. The caption file will be created when videos are saved.

# Maintenance

## Log Export

Run DJI Pilot 2, tap HMS, then Manage Logs, and select H30 or H30T to export the log to the microSD card of the payload.

## Firmware Update

### Using DJI Pilot 2

#### Online Updating

1. Make sure that the payload is correctly installed on the aircraft and the aircraft, remote controller, and other DJI devices are powered on. Make sure all the devices are connected.
2. Run DJI Pilot 2, tap HMS, Firmware Update, and then Update All to update the firmware.

#### Offline Updating

An offline firmware package can be downloaded from the DJI official website to an external storage device such as a microSD card or USB thumb drive. Run DJI Pilot 2, tap HMS, and then Firmware Update. Tap Offline Update to select the firmware package from the external storage device and tap Update All to update.

### Using microSD Card

1. Make sure that the payload is mounted onto the aircraft and the aircraft is powered off. Check that there is enough free space on the microSD card and the Intelligent Flight Batteries are fully charged.
2. Visit the Zenmuse H30 series product page on the DJI official website and go to Downloads.
3. Download the latest firmware.
4. Once downloaded, copy the firmware file to the root directory of the microSD card.
5. Insert the microSD card into the microSD card slot of the payload.
6. Power on the aircraft. The payload will perform an auto-check and start to update automatically. The payload will beep to indicate the status of the firmware update.
7. Restart the device after the firmware update is complete.

## Update Status Alarm

Alarm	Description
1 short beep	Firmware update detected. Preparing to update.
4 short beeps	Updating firmware. Do not stop update.
1 long beep followed by 2 short beeps	Firmware update successful.
Continuous long beep	Firmware update failed. Try again. Contact DJI support if the problem persists.



- Make sure that there is only one firmware update file on the microSD card.
- DO NOT power off the aircraft or detach the gimbal and camera while updating the firmware. It is recommended to delete the firmware update file on the microSD card once the firmware is updated.

# Appendix

## Specifications

### General

Dimensions	170×145×165 mm
Weight	920±5 g
Power	H30: 26 W H30T: 28 W
IP Rating	IP54
Supported Aircraft	Matrice 350 RTK Matrice 300 RTK (requires DJI RC Plus)
Operating Temperature	-20° to 50° C (-4° to 122° F)
Storage Temperature	-20° to 60° C (-4° to 122° F)
Maximum Ground Speed <sup>[1]</sup>	20 m/s

### Gimbal

Stabilization System	3-axis (tilt, roll, pan)
Angular Vibration Range	Hover: ±0.002° Flight: ±0.004°
Mounting	Detachable DJI SKYPORT
Mechanical Range	Tilt: -132.5° to +73° Roll: ±60° Pan: ±328° (structural limit, not controllable range)
Controllable Range	Tilt: -120° to +60°; Pan: ±320° (downward gimbal) Tilt: -60° to +120°; Pan: ±320° (upward gimbal)
Operation Mode	Follow/Free/Re-center

### Zoom Camera (H30/H30T)

Image Sensor	Effective Pixels: 40M, 1/1.8" CMOS
Lens	Focal length: 7.1-172mm (equivalent: 33.4-809.3mm) Aperture: f/1.6-f/5.2 DFOV: 66.7°-2.9°
Focus Mode	MF/AFC/AFS
Exposure Mode	Manual, Auto
Exposure Compensation	±3.0 (1/3 increments)
Metering Mode	Spot Metering, Average Metering

AE Lock	Supported
Electronic Shutter Speed	1/8000-2 s
ISO Range	Single Shot: 100-25600 Night Scene: 100-819200
Video Resolution	Single Shot: 3840×2160@30fps, 1920×1080@30fps Night Scene: 1920×1080@25fps, 1920×1080@15fps, 1920×1080@5fps
Video Format	MP4
Video Caption	Supported
Video Codec and Bit Rate Strategy	H.264, H.265 CBR, VBR
Max Photo Size	7328×5496, 3664×2748
Photo Format	JPG
<b>Wide Camera (H30/H30T)</b>	
Image Sensor	Effective Pixels: 48M, 1/1.3"CMOS
Lens	Focal length: 6.72mm (equivalent: 24mm) Aperture: f/1.7 DFOV: 82.1°
Focus Mode	MF/AFC/AFS
Exposure Mode	Manual, Auto
Exposure Compensation	±3.0 (1/3 increments)
Metering Mode	Spot Metering, Average Metering
AE Lock	Supported
Electronic Shutter Speed	1/8000-2 s
ISO Range	Single Shot: 100-25600 Night Scene: 100-409600
Video Resolution	Single Shot: 3840×2160@30fps, 1920×1080@30fps Night Scene: 1920×1080@25fps, 1920×1080@15fps, 1920×1080@5fps
Video Format	MP4
Video Caption	Supported
Video Codec and Bit Rate Strategy	H.264, H.265 CBR, VBR
Max Photo Size	8064×6048, 4032×3024
Photo Format	JPG

<b>Infrared Thermal Camera (H30T only)</b>	
Thermal Imager	Uncooled VOx Microbolometer
Lens	Focal length: 24mm (equivalent: 52mm) Aperture: f/0.95 DFOV: 45.2°
Digital Zoom Equivalent	32×
Video Resolution	1280×1024@30fps
Video Format	MP4
Video Caption	Supported
Video Codec and Bit Rate Strategy	H264, H265 CBR, VBR
Photo Resolution	1280×1024
Photo Format	R-JPEG
Pixel Pitch	12 μm
Spectral Band	8-14 μm
Noise Equivalent Temperature Difference (NETD)	≤ 50 mk@F1.0
Temperature Measurement Method	Spot Measurement, Area Measurement, Center Point Temperature Measurement
Temperature Measurement Range	High Gain: -20° to 150° C (-4° to 302° F), -20° to 450° C (-4° to 842° F) (With Infrared Density Filter) Low Gain: 0° to 600° C (32° to 1112° F), 0° to 1600° C (32° to 2912° F) (With Infrared Density Filter)
Temperature Alert	Supported
Sun Burn Protection	Supported
FFC	Auto/Manual
Palette	White Hot, Black Hot, Tint, Iron Red, Rainbow 1, Rainbow 2, Medical, Arctic, Fulgurite, Hot Iron
<b>Laser Rangefinder (H30/H30T)</b>	
Wavelength	905 nm
Measurement Range <sup>[2]</sup>	3-3000 m Range for common objects: Grassland 2000 m, woodland 1900 m, road surface 1700 m <sup>[3]</sup>
Measurement Accuracy	≤ 500 m: ±(0.2 m + measurement distance×0.15%) > 500 m: ±1.0 m
Laser Spot Size	@100 m: Approx. 50×450 mm @1000 m: Approx. 450×4500 mm

Safety Regulation Level	Class 1
Accessible Emission Limit (AEL)	260 nJ
Reference Aperture	18 mm
Max Laser Pulse Emission Power Within 5 Nanoseconds	52 W
<b>NIR Auxiliary Light (H30/H30T)</b>	
Wavelength	850 nm
FOV	4.6±0.6° (Round)
Safety Regulation Level	Class 1
Illumination Range	@100 m: Approx. 8m diameter circle
<b>Data Storage<sup>[5]</sup></b>	
Supported microSD Cards	U3/Class10/V30 or above is required, or use a memory card from the recommended list.
Supported File System	exFAT
Recommended microSD Cards	Sandisk Extreme Pro V30 A1 32GB microSDHC Lexar 1066x V30 A2 64GB/128GB/256GB/512GB microSDXC Kingston CANVAS GO! Plus V30 A2 64GB/128GB/256GB/512GB microSDXC
<b>Processing Data</b>	
Mapping Software	DJI Terra, DJI FlightHub 2
Infrared Analysis Software	DJI Thermal Analysis Tool 3

- [1] The gimbal may vibrate if exceeding the maximum ground speed. Image quality may be affected.
- [2] The rangefinding data may vary based on the material and shape of the tested object as well as the impact of gimbal angle, environmental light, and weather conditions such as rain or fog. If a laser pulse hits multiple targets, its energy is dispersed, which may reduce the measurable distance.
- [3] For a flat surface subject (when the subject size exceeded the laser beam diameter), with an atmospheric visibility of 23 km (the laser has a shorter range in clear conditions compared with overcast conditions), the laser impinges at an oblique angle (with an angle of incidence of approx. 0.2 radians).
- [4] Zenmuse H30 series supports the Security Code function. Go to Data and Privacy in DJI Pilot 2 and set the code to encrypt the microSD card installed on the camera. Download DJI Decrypt Tool from the DJI official website to decrypt the microSD card on a Windows computer and access the card content.

## Infrared Parameters

### Palettes

Distinct colors are used to show temperature differences in the thermal image using grayscale intensity. The temperature range of the image is mapped to 256 colors and displayed in the 8-bit JPEG or MP4 format. The infrared thermal camera offers a variety of palette options, the table shows all palette options.

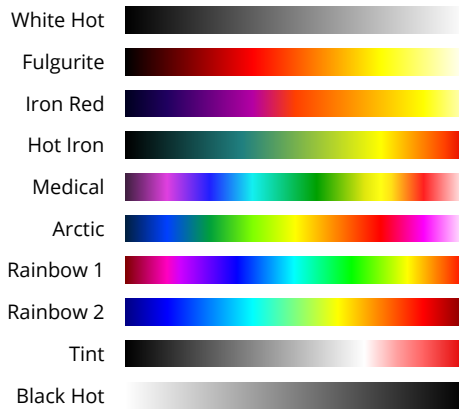

Palette	Description
White Hot	The mostly commonly used pseudo color, using white for high temperatures and black for low temperatures, which is a natural association for people.
Fulgurite	Dark red represents low temperatures and white represents high temperatures. The warm tone of this palette aligns with peoples' association with hot temperatures.
Iron Red	This palette displays nuanced differences in heat signatures, quickly displaying anomalies and human bodies. Hotter objects appear as light warm colors and colder objects appear as dark cool colors.
Hot Iron	Red represents high temperatures, and cool colors represent low temperatures. Users are able to identify hot target quickly, while showing the details of cool targets.
Medical	This palette shows nuanced differences in temperatures, and is therefore ideal for scenarios with small temperature changes. In environments with low contrast, it is still able to detect objects and slight temperature changes. It is mainly used in the medical field for human body temperatures.
Arctic	Uses the same palette as Medical, except switching the purple for a cool blue to better reflect temperature changes.



Rainbow 1	Similar to Medical, it reduces the warm color ratio and increases the cold color ratio for high temperature targets to better show the details of cool targets.
Rainbow 2	The color transition is reduced and the warm and cold colors are moderately proportioned, which helps show the details of high and low temperature targets at the same time.
Tint	Uses black and white for low temperatures and bright red for high temperatures, allowing users to detect high temperature objects quickly. Mainly used for high-contrast environments, ideal for quickly and accurately identifying high temperature objects.
Black Hot	The opposite to White Hot, using black for warmer objects and white for cooler objects. The heat distribution of high temperature objects can be better observed when outdoors.

## Emissivity

Emissivity is the ability of the object to emit infrared radiation, which is affected by factors such as the material, the roughness or degree of oxidation of the object's surface. The table below shows the emissivity of common objects for reference.

Material	Emissivity
Glass	0.85
Ceramics	0.95
Concrete	0.95
Plastic (opaque)	0.95
Paper	0.95
Soil	0.92 (dry); 0.95 (wet)
Aluminum	0.3
Brass	0.5
Iron	0.7
Lead	0.5
Steel	0.8
Water	0.93
Oil	0.94

WE ARE HERE FOR YOU



Contact  
DJI SUPPORT

This content is subject to change.

<https://enterprise.dji.com/zenmuse-h30-series/downloads>

If you have any questions about this document, please contact DJI by sending a message to [DocSupport@dji.com](mailto:DocSupport@dji.com).

DJI and ZENMUSE are trademarks of DJI.  
Copyright © 2024 DJI All Rights Reserved.